Comfort-Cire®

Century®

PARTS LIST

**Inverter Single Zone
Outdoor Ductless Mini-Split**

A-VMH09SU-1

EXPLODED VIEW

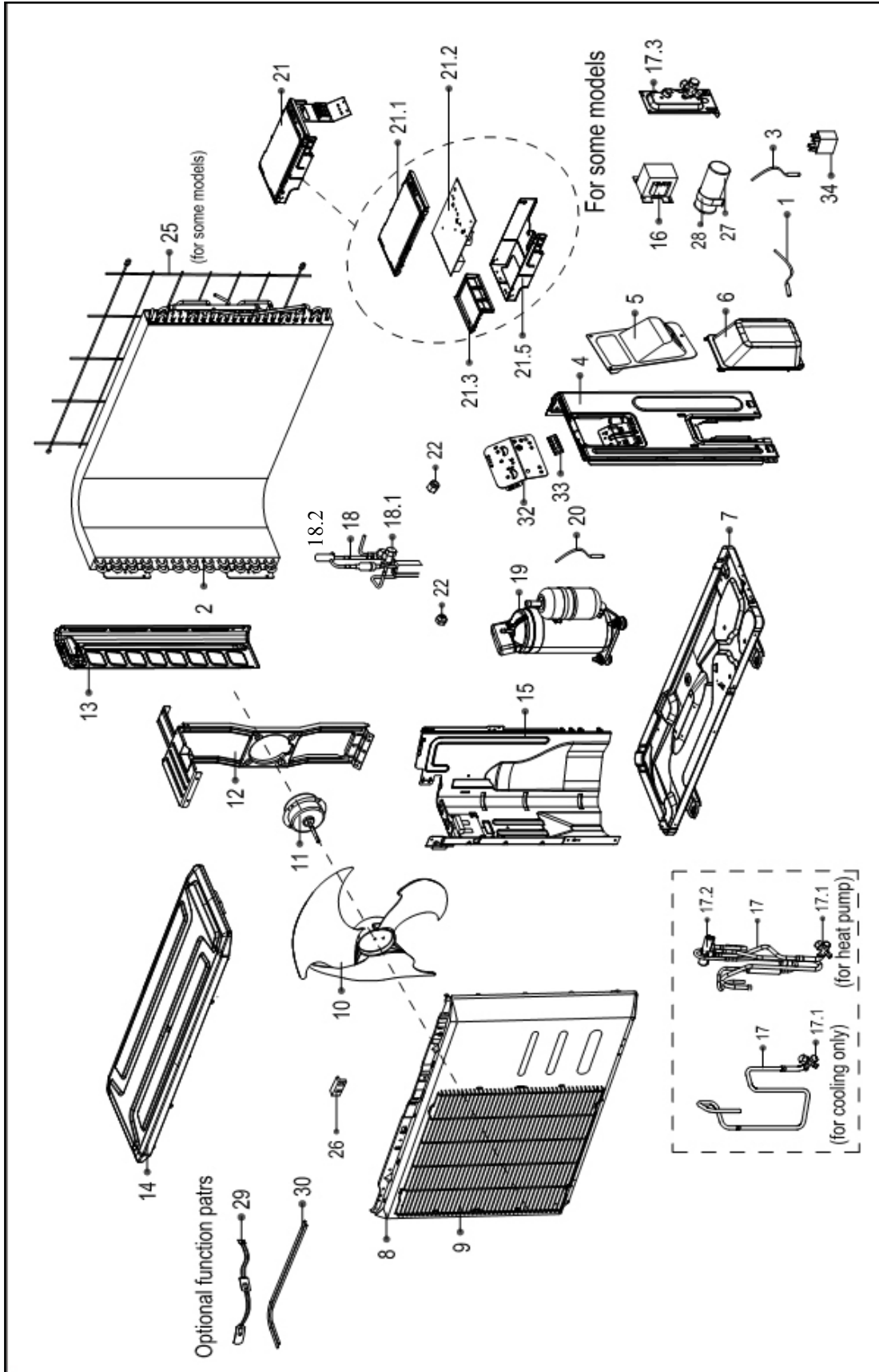

REPLACEMENT PARTS

Location	Part Name	Quantity	Part No.
1	Ambient temperature sensor assembly	1	11201007000039
2	Condenser assembly	1	15822000002212
3	Pipe temperature sensor assembly	1	11201007000069
4	Right clapboard assembly	1	12222000005745
5	Big handle	1	12222000005102
6	Line set connection cover	1	12122000007150
7	Chassis assembly	1	12222000004326
8	Front panel	1	12222000004463
9	Air outlet grille	1	12222000007424
10	Axial flow fan	1	12100105000051
11	Fan Motor	1	11002015000041
12	Supporter assembly of fan motor	1	12222200001462
13	Left supporter	1	12222000006504
14	Top cover assembly	1	12222200001291
15	Partition board assembly	1	12222200001146
16	Reactor	1	17400306000053
17	4-Way valve assembly	1	15422000004033
17.1	Gas valve	1	15500204000021
17.2	4-Way valve	1	15500216000028
17.3	Valve plate	1	12222000002571
18	Liquid valve assembly	1	15422000004032
18.1	Liquid valve	1	15500208000028
18.2	Electronic expansion valve	1	15500213000178
19	Compressor	1	11103020000215
20	Discharge temperature sensor assembly	1	11201007000005
21	Electronic control box assembly	1	17222000008508
21.1	Cover of electronic control box	1	12122000006856
21.2	Outdoor power board assembly	1	17122000017248
21.3	Support of electronic control box	1	12122000014683
21.5	Electronic installing box	1	12222000001325
22	Copper nut	1	15500406000010
22	Copper nut	1	15500406000016
25	Rear net	1	12222000003622
30	Electric heater of chassis	1	17402002000042
32	Electronic installing box	1	12222000002259
33	Wire joint	1	17400401000075
41	Drain pipe	1	12100509000059

Due to ongoing product improvements, specifications and dimensions are subject to change and correction without notice or incurring obligations. Determining the application and suitability for use of any product is the responsibility of the installer. Additionally, the installer is responsible for verifying dimensional data on the actual product prior to beginning any installation preparations.

Incentive and rebate programs have precise requirements as to product performance and certification. All products meet applicable regulations in effect on date of manufacture; however, certifications are not necessarily granted for the life of a product. Therefore, it is the responsibility of the applicant to determine whether a specific model qualifies for these incentive/rebate programs.

Comfort-Aire®  **Century**®